

SureStart

Three Phase Soft Starters

Specification Catalog

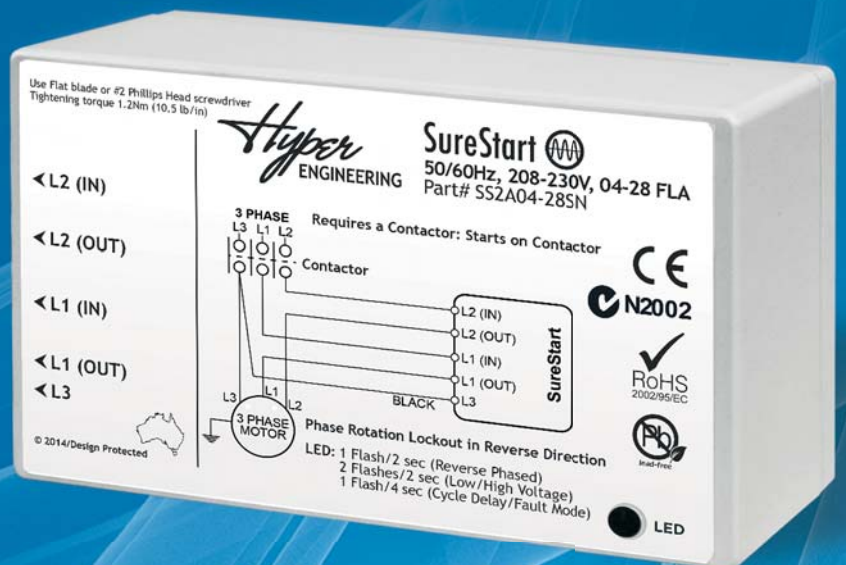

Table of Contents

Introduction.....	4
SureStart	4
Background	4
In-Rush Current.....	5
Measuring In-Rush.....	5
The SureStart Difference	7
SureStart Operation	8
LED Flash Codes	8
Operation Flow Chart	9
Model Nomenclature	10
Selection Example	10
Dimensional Data	11
Mounting Positions	11
Characteristics	12
Application Notes	12
Installation Notes	13
SureStart Compatibility Guide	14
Schematics.....	14
Declaration of Conformity.....	15
Definitions.....	16
Revision Table	18

Introduction

The Sure-Start Series soft-starter was the first of its kind when it was invented by Hyper Engineering over a decade ago in Wollongong, Australia. It was originally invented for use in the residential heating, ventilation, and air-conditioning (HVAC) industry in Australia and Europe. In recent years, Hyper has expanded Sure-Start technology into commercial HVAC by offering 3 phase versions in commercial voltages. Whether it is for residential or commercial applications, Sure-Start's continued success worldwide is a testament to its reliability and performance that can be rivaled by none other.

SureStart

Hyper Engineering has expanded Sure-Start technology into the commercial realm by introducing the Sure-Start for three phase compressors. Sure-Start for commercial applications is specifically engineered to optimize starting of large scroll compressors up to 20 horsepower. Commercial compressors exhibit a significant amount of torque at startup often generating tremendous noise and mechanical shock in system piping. Refrigerant piping in commercial air conditioning becomes stressed and eventually cracks creating problems for the maintenance staff, building owner, and ultimately building occupants.

SureStart offers the following benefits:

- 70% reduction in start-up torque
- 40% reduction in direct on-line (DOL) or in-rush current
- Sophisticated under voltage protection
- Self-adjusting from 2-20 hp for optimal start performance
- 50/60 Hz compatible
- UL, CE, EMC, and RoHS compliant
- Tolerant to "dirty power" conditions

- Phase reversal protection
- Available in standard commercial voltages
- Versions available for retrofit installations for OEM production use
- Fault LED
- Internal current limiting

Background

Air conditioning and heat pump equipment is designed to move thermal energy to heat or cool a defined space. Energy is moved through the air conditioner by a compressor which is an electrically driven pump that compresses refrigerant as it pumps to a heat exchanger. Compressors are the heart of air conditioning equipment so it is important to protect it against failure. Inside of every compressor is an electric motor that draws a significant electrical current at startup. This startup current is often referred to as the instantaneous current, in-rush current, locked-rotor amps (LRA), or direct-on-line (DOL) current. In-rush current on the air conditioner is generally between 5-8 times higher than the current consumed by the compressor during normal operation. As the name suggests, in-rush current is very brief lasting for a fraction of a second until the motor begins operating at normal speed. This time period may appear trivial; however, it is the cause of big headaches for building owners, power companies, and equipment manufacturers. Here are some common problems created by high in-rush current in commercial buildings.

- Flickering of lights
- Nuisance trips on safety protection equipment
- Disrupts sensitive electronics such as computers
- Increased stress on the motor which reduces the reliability of the air conditioning equipment.
- Higher installation cost due to insufficient transformer sizing
- Increased noise and vibration at compressor startup

SureStart Module

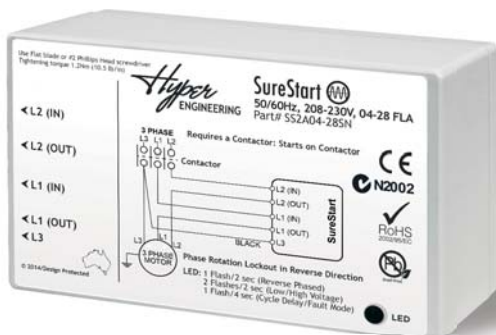

Most of the time contractors are installing expensive solutions such as variable frequency drives (VFDs) to slowly ramp up the compressor to try to eliminate these problems. Unfortunately, VFDs are a costly solution that reduces the efficiency of standard three phase motor and ultimately the heat pump or air conditioner. Installing Sure-Start corrects these problems by significantly reducing start current, optimizing the start time to the compressor size, power supply and loading while providing vital protection to the compressors, and promoting improved reliability at startup.

In-Rush Current

Motor in-rush occurs due to low resistance in motor windings essentially acting like a short circuit. This temporary short circuit causes an immediate spike in current and simultaneous drop in supply Voltage. Voltage drops for air conditioning compressors are often 15% or more which is 3-4 times greater than what most electrical power distributors prefer. The more frequently the compressor starts, the more noticeable the problem becomes. For most buildings in the US, air conditioners usually start at a rate of 6-10 starts per hour.

As government regulations tighten, calling for higher efficiency air conditioning, compressor manufacturers have responded with higher efficiency motors in the compressors. The downside to improved efficiency is that in-rush current generally goes up as motor efficiency increases. Figure 1 is a graph of typical in-rush current for air conditioners in the US along with the SureStart reduced in-rush current.

Measuring In-Rush

The effect of these electrical spikes can be observed by watching the lights flicker; however, this does not help quantify the problem. In order to properly measure in-rush current, the right tool is needed for the job. In this case, that tool is an oscilloscope which has the ability to observe electrical signals with great detail. Oscilloscopes are used by engineers in a laboratory environment to study the magnitude and shape of signals at specific points in time. An oscilloscope is an expensive device that is more powerful than what is needed by most service technicians for diagnostic use in the field. Instead technicians carry a handheld device called a digital multi-meter (DMM) that is capable of basic current, voltage, and resistance measurements. Some DMMs are also able to capture maximum amperage or current value as well. It is likely that a technician will use a DMM when trying to capture the in-rush current of compressor at start-up. Unfortunately, it is likely this maximum value does not reflect the true instantaneous spike in current. The DMM is only capable of recording current at defined time intervals. If the time interval of the event is too fast the DMM will have a portion of the interval where it recorded very low values. Low values will shift the average down making it appear less significant. The faster the event the less likely the DMM is to display accurate results. Furthermore, the DMM is limited on the type of signal that it can detect. If the signal is smooth and characteristic of an ideal sine waveform; then it is

likely to be okay. However, if the signal is a complicated waveform like measuring with a SureStart in the circuit; then it won't be accurate. This is an important concept since the wrong tool used for measurement may lead to false interpretation therefore not actually solving the problem.

Figure 1: Normal 20 hp LRA vs SureStart

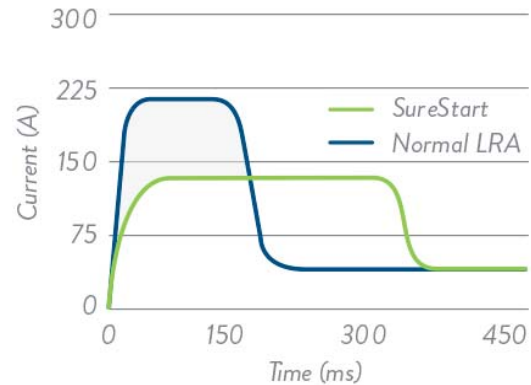

Before

Locked Rotor Amperage (LRA)

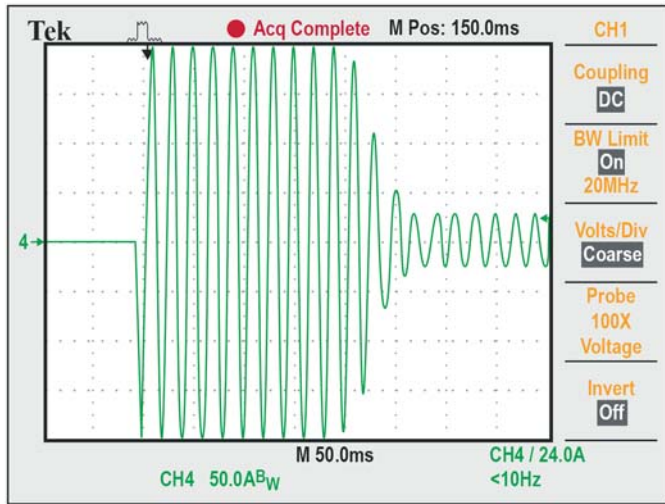

After

Using SureStart

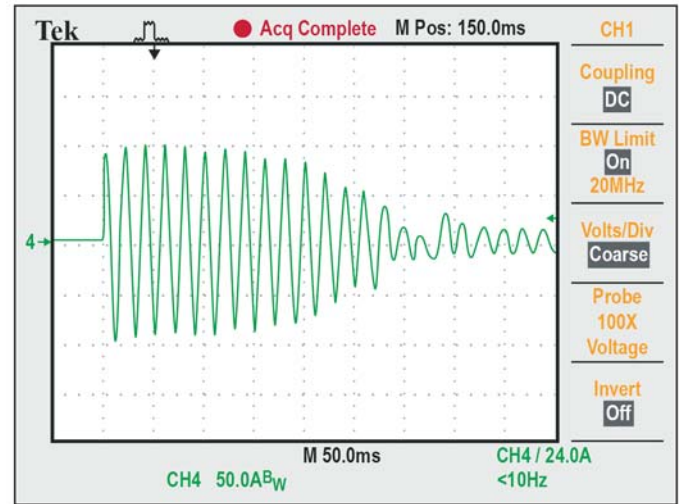

The SureStart Difference

The term “softstart” is used generically when referring to devices such as SureStart. It is worthwhile to note that SureStart is not a “hard start” device. As the name implies, it is a SureStart™ which ensures the compressors starts optimally every time by not delivering too much nor too little torque.

SureStart applies power electronics combined with intelligent software to provide optimal mechanical advantage during motor starting. SureStart technology maintains optimal torque while maximizing starting efficiency over a range of power supply conditions.

By comparison, conventional softstarters normally have only a Voltage ramp up where only ramp times are available for control separately.

- SureStart does not compromise on the minimum torque needed to start the motor.
- It eliminates the mechanical shock for a three phase motor startup and helps extend the life of foundation bolts and system piping.
- It automatically adjusts the time needed to achieve rotational speed across wide range of compressor sizes.
- It compensates for abnormal power conditions such as high cable impedance, low voltage or high voltage conditions.
- It has a sophisticated learning algorithm to optimize the starting time performance based upon various factors some of them being: the line impedance(reflected from the input voltage to motor) and the time it takes for the motor to reach up to full speed. This ensures auto regulation of start performance for different sized motors without any human intervention.
- The SureStart also reduces the voltage dip in the power line during starting.
- Light flickering is reduced during start up when units have a SureStart in the circuit.
- Built-in firmware inside SureStart helps eliminate arc damage to the motor contactor due to chattering.
- SureStart is out of the circuit after startup. It consumes less than 2W average in running mode.
- The SureStart protects against motor phase reversal by preventing the motor from starting up in event of intermittent switching of any two input supply phases. Reverse rotation due to phase reversal can quickly damage the motor load setup, if not prevented immediately.
- SureStart will also protect the motor by not allowing it to start under adverse low voltage or high voltage conditions.
- Loss of power detection includes sensing of low voltage sags and intermittent power drop outs (lasting 100 milliseconds or higher).
- SureStart models are available in different voltage ratings to suit standard voltage supply ratings prevalent in various parts of the world.



HVAC/R



Marine



RV/Luxury Buses



Military/Government



Solar Power



Backup Generators

Application Types

The SureStart is versatile enough to be used in many applications other than HVAC/R with guidance from our Hyper Engineering Technical Support.

- HVAC/R
- Marine
- Compressors
- Solar Power
- RV/Truck
- Military/Government

SureStart Operation

When the system control calls for compressor operation, the compressor contactor will energize. If the supply voltage to the SureStart is less than “Minimum Startup Voltage” or higher than “Maximum High Voltage”, a 50 second delay is initiated. At the end of the delay, another attempt to start the compressor will begin unless the supply voltage remains unchanged. SureStart uses an optimized starting process that learns the starting characteristics of the compressor to further refine the starting cycle on each recurring start. If the compressor fails to start, the module will terminate the start attempt after 1 second and initiate a 3 minute lockout before attempting a restart. If the supply voltage falls below “Shutdown on Low voltage” limit for 2 seconds or below 70% of rated supply for 0.1 seconds while the compressor is running, the module will stop the compressor and initiate a 3 minute lockout. Similar lockout is ensured when the supply voltage exceeds the “Shutdown on High voltage” limit for 2 seconds. A restart will be attempted after 3 minutes if the supply voltage is restored within operating range. This is done to protect the compressor against a sudden drop in supply voltage or rapid voltage swells.

SureStart is able to detect brief interruptions in power, when the interruption is 0.1 seconds or longer. When a power interrupt is detected, SureStart will shut down the compressor for 3 minutes. SureStart is also able to determine if the compressor is fed with a reversed phase sequence. Under such conditions, a motor will rotate in reverse direction which if left unattended can permanently damage the compressor scroll or other connected load setup in most applications. If this condition is detected, SureStart will stop the compressor for 3 minutes before a restart is attempted. Motor is only restarted once the phase sequence has been restored.

LED Flash Codes

A Red LED indicator will flash under the following conditions.

[NOTE: LED fault indicator is turned off in normal running mode.]

- a) Reverse Phase: (1 / 2 secs)
- b) Fault Mode/Cycle Delay: (1 / 4 secs)
- c) Low Voltage/ Over Voltage: (2 / 2 secs)

Flash Code (Reverse Phase: (1 / 2 secs))

- Displayed if the supply "Phase Sequence" gets reversed before or after a start.
- Re-start is attempted after 3 minutes.

Flash Code (Fault Mode / Cycle Delay: (1 / 4 secs))

- Displayed for "Cycle delay" between two consecutive softstarts or other faults mentioned below.
- Re-start is attempted after a default period of 3 minutes.
- Other possible reasons for this Fault mode indicator can be due to
 - a failed Softstart attempt,
 - intermittent power loss (duration longer than 100ms), or
 - frequency out of range

Flash Code (Low Voltage / Over Voltage: 2 / 2 secs)

- Displayed for "Low supply voltage" or "High supply voltage" before or after a softstart.
- If voltage is out of range before a start, a re-start is attempted after 50 seconds.
- If voltage is out of range after a start, a re-start is attempted after 3 minutes.

SureStart - Basic Operation

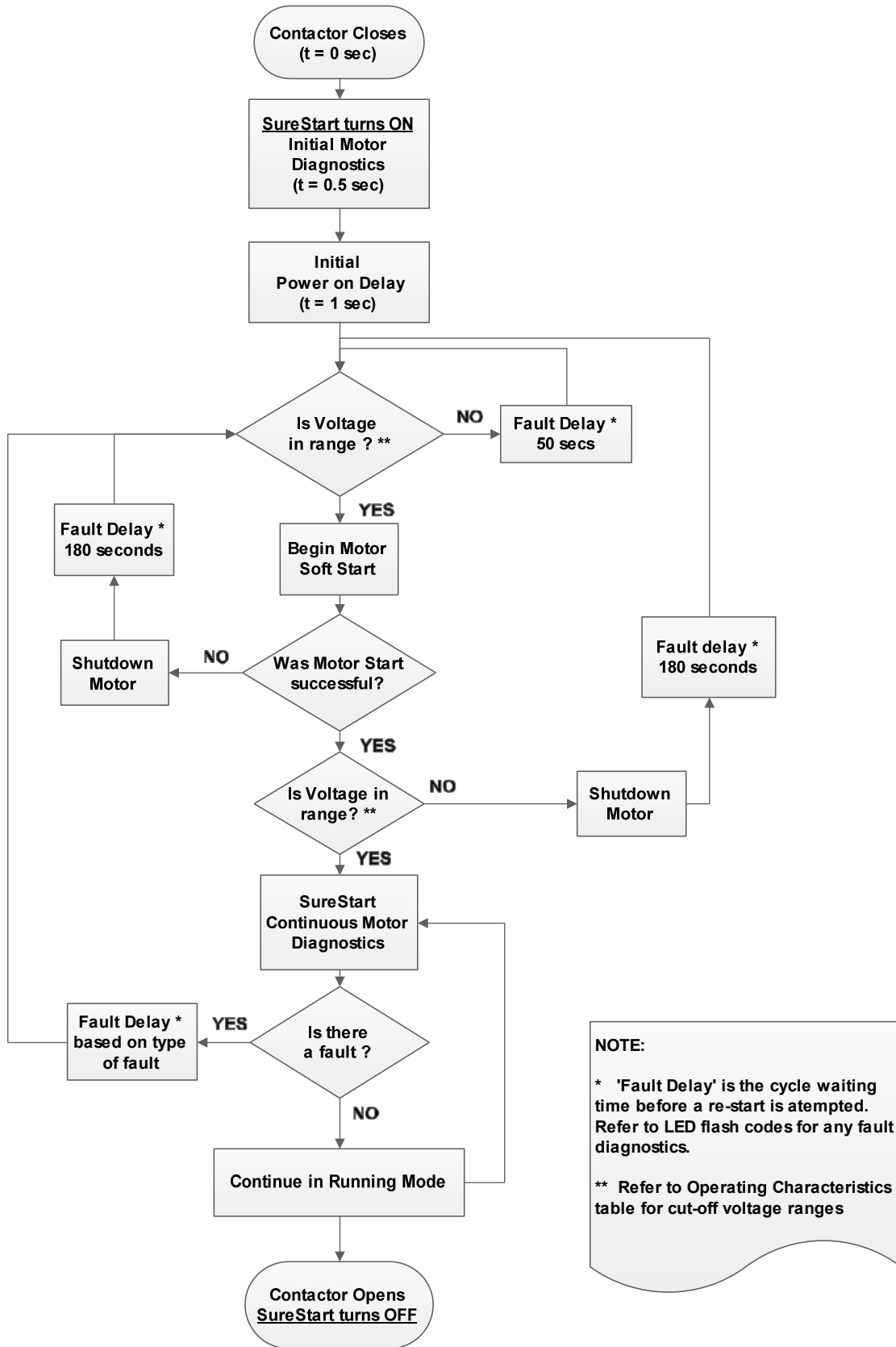

NOTE:

* 'Fault Delay' is the cycle waiting time before a re-start is attempted. Refer to LED flash codes for any fault diagnostics.

** Refer to Operating Characteristics table for cut-off voltage ranges

Model Nomenclature

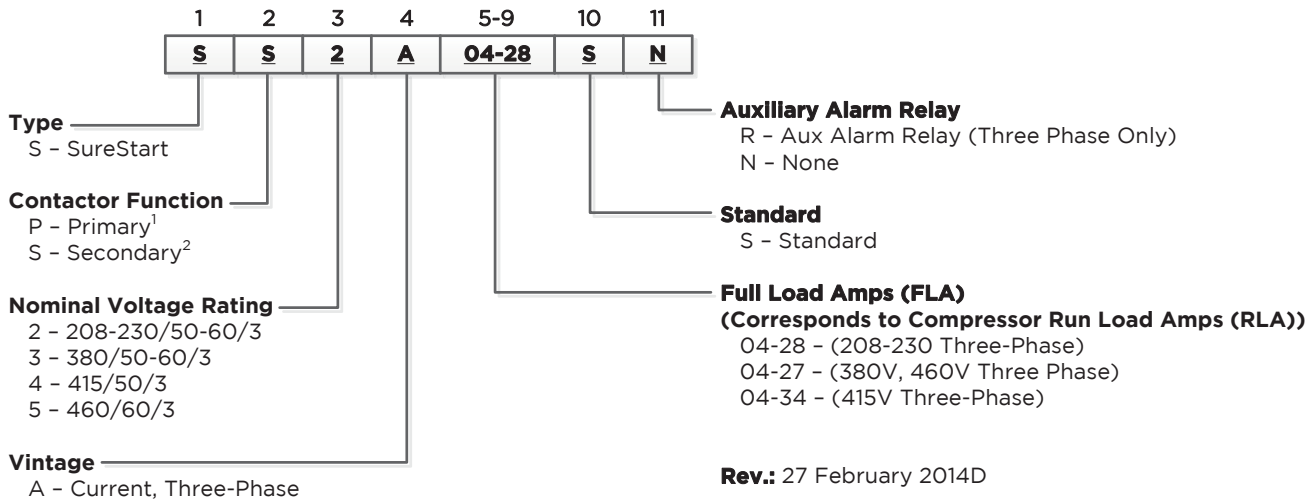

Notes:

- 1 - Not available in the United States.
- 2 - Primary includes a contactor. Secondary operates in series with contactor.

Selection Example

1. Locate Compressor Data. Example Copeland ZP51 in Model 120 Geothermal Unit. Electrical Table is below.

Model	Rated Voltage	Voltage Min/Max	Compressor*				Fan Motor***	
			MCC	RLA	LRA	LRA**	FLA	HP
084	460/60/3	414/506	9.0	5.8	38.0	23.0	2.4	1.5
096	460/60/3	414/506	9.5	6.1	41.0	25.0	3.1	2.0
120	460/60/3	414/506	12.1	7.7	52.0	31.0	4.3	3.0

- * - Rating per compressor
- ** - Rating with SureStart
- *** - Rating per motor

2. or from the equipment nameplate.

Model 120 Heat Pump	
Voltage	460/60/3
Compressor MCC	12.1
Compressor RLA	7.7
Compressor LRA	52
Fan Mtr FLA	4.3
Total FLA	19.8
Min Circ Amp	21.7
Max Fuse/HACR	25

3. Find rated FLA (RLA for Compressor), and Rated Voltage:
 - Compressor RLA is 7.7 Amps from chart or nameplate for Model 120
 - Compressor Rated Voltage is 460V/60Hz/3ph
4. Select SureStart Model From Nomenclature:
 - SS5A04-27SN rated for 460V/60Hz/3ph and 4-27 FLA (RLA on compressors)

Dimensional Data

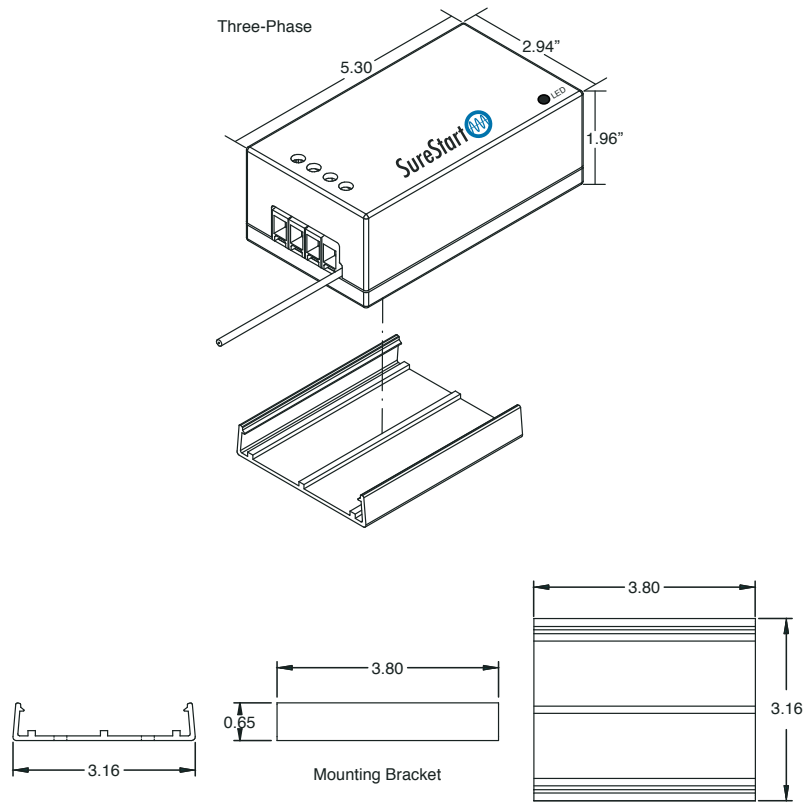

Approved Mounting Positions

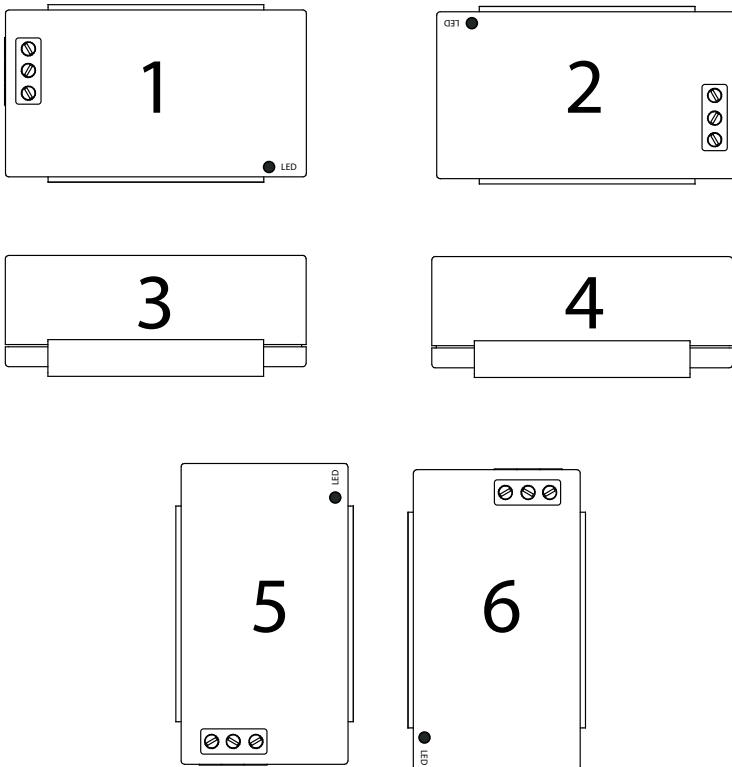

Not Approved

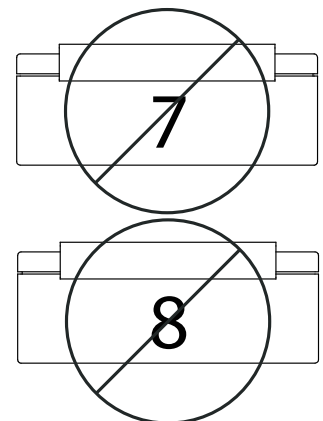

Physical Characteristics

SureStart Model	Three Phase		
	SS2A04-28	SS3A04-27	SS4A04-34 SS5A04-27
Storage Temperature, °F [°C]	-40 [-40] to 185 [85]		
Case Material	ABS Flameproof UL-94 V0		
IP Rating	IP207		
Line Conductor, AWG	14 - 6	14 - 6	14 - 6
Line Conductor Strip Length, in. [mm]	0.47 [12]	0.47 [12]	0.47 [12]
Minimum Line Conductor Length, in. [mm]	15.7 [400]	15.7 [400]	15.7 [400]
Line Terminal Tightening Torque, in-lbs [N-m]	10.5 [1.2]	10.5 [1.2]	10.5 [1.2]
T3 Wire Gauge, AWG	18	18	18
T3 Wire Lead Length, in. [mm]	24.4 [620]	24.4 [620]	24.4 [620]
T3 Wire Termination, in. [mm]	0.25 [6.35] insulated quick connect		

03/06/14

Operating Characteristics

SureStart Model	Three Phase			
	SS2A04-28	SS3A04-27	SS4A04-34	SS5A04-27
Rated Voltage, VAC	208-230	380	415	460
Rated Phase	3	3	3	3
Rated Frequency, Hz	50/60	50/60	50	60
Maximum Load Current, Amps	38	38	38	38
Maximum Starting Current, Amps	150	150	150	150
Number of Starts/Hour (Evenly Distributed)	20	20	20	20
Short Circuit Current Rating (SCCR), kA	5	5	5	5
Shutdown on Low Voltage	176	323	353	391
Minimum Startup Voltage	187	342	373	414
Maximum High Voltage	253	422	460	510
Operating Ambient, °F [°C]	-4 [-20] to 140 [60]			
Life Expectancy (At Maximum Rated Load)	Minimum 100,000 Operations			

03/06/14

Software Characteristics

SureStart Model	Three Phase		
	SS2A04-28	SS3A04-27	SS4A04-34 SS5A04-27
Software Fault Delay, seconds	180	180	180
Initial Power on Delay, seconds, 60 Hz [50Hz]	1 [1]	1 [1]	1 [1]
Power Loss Reset, milliseconds	100	100	100
Contactors Chatter Protection	Yes	Yes	Yes
Reverse Phase Protection	Yes	Yes	Yes
Software Optimization	Auto tune		

10/01/13

Application Notes

Scroll Compressors

SureStart technology can be applied to most scroll compressors as long as they fall within the correct range of Full Load amperage rating of the listed models. All scroll compressors have an internal equalization mechanism. SureStart is not compatible with all Digital scroll compressors. Consult Hyper Engineering when using SureStart on Digital compressors.

Reciprocating & Rotary Compressors

SureStart technology can be applied to most reciprocating and rotary compressors as long as they fall within the correct range of Full Load amperage rating of the listed models. Systems using these types of compressors must equalize differential pressure across the compressor during off cycle. SureStart is not intended to start compressors that are under a large differential pressure at startup. Doing so will compromise the life of the SureStart.

Other Applications

For all other applications please consult Hyper Engineering Technical Support

Inverter Driven Compressors

SureStart cannot be applied to inverter driven compressors.

Schematics

Refer to the wiring diagram Figure 1, which shows how the SureStart module should be wired into a new or existing system. Conductor type shall be stranded copper with a 75°C minimum temperature rating. The system must be grounded and all applicable codes adhered to.

Installation Notes



WARNING!

Remove all other starters and drives in the circuit. The module shall not be installed into an enclosure smaller than 10x8x6 inches.

SureStart Compatibility Guide

Nominal Supply Voltage*	Three Phase			
	SS2A04-28	SS3A04-27	SS4A04-34	SS5A04-27
208-230/50-60/3	•			
380/50-60/3		•		
415/50/3			•	
460/60/3				•
Full Load Amperage, FLA (Typical)	04-28	04-27	04-34	04-27

* - Voltage/Hz/Phase

11/21/13

Wiring Schematics

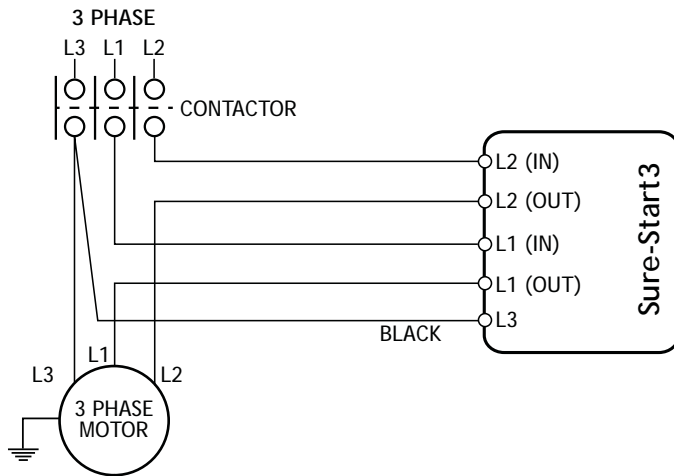

CAUTION: SureStart must be installed in a location that ensures that the external heat from a hot gas line, compressor discharge piping, or similar heat source will not cause damage. Minimum 3" [76mm] clearance is recommended.

Declaration of Conformity

SureStart technology has been tested and certified under the following standards that apply.

For United States, Canada, & Mexico

UL 508/ CSA 22.2 # 14 (ETL control # 4004190)

For European Union, Australia, and other countries accepting CE Marking

Low Voltage Directive (LVD)

IEC/ EN 60947-4-2: Low Voltage switchgear and control gear: contactors and motor-starters

IEC/ EN 60335-1 & IEC/ EN 60335-2-40: Safety requirements for electrical heat pumps, air conditioners, dehumidifiers.

Electromagnetic Compliance (EMC)

IEC/ EN 55014-1 Conducted & radiated emissions

IEC/ EN 61000-3-11 Flicker

IEC/ EN 61000-3-12 Harmonics emissions

IEC/ EN 61000-3-2 Harmonic current emissions

IEC/ EN 55014-2 Conducted & radiated immunity

IEC/ EN 61000-6-1 Immunity for residential, light commercial, and light industrial

IEC EN 61000-3-3 Voltage fluctuations

IEC/ EN 61000-4-2 Electrostatic discharge (ESD) immunity test

IEC/ EN 61000-4-3 Radiated, radio-frequency, electromagnetic field immunity test

IEC/ EN 61000-4-4 Electrical fast transient/burst immunity test

IEC/ EN 61000-4-5 Surge Immunity Test

IEC/ EN 61000-4-6 Conducted radio-frequency immunity

IEC/ EN 61000-4-11 Voltage dips, short interruptions, and voltage variations immunity tests

EMC compliance tested in accordance with:

ANSI C63.4

EN55022 + A1:2000 + A2:2003

CISPR16 and CISPR22

VCCI V-3/2007.04

Definitions

Case Material - SureStart enclosure material

Line conductor - Wiring that connects to the “IN” and “OUT” for T1/T2 connections on three phase SureStart.

Line Conductor Strip Length - This is the length of insulation stripped away in order to properly insert into the SureStart.

Line Terminal Tightening Torque - The necessary torque needed to secure line conductors to the SureStart.

Rated Voltage - This is the nominal supply voltage to the SureStart.

Rated Frequency - This is the nominal frequency, Hz, of the power supply to the SureStart.

Maximum Starting Current - The maximum current at motor startup for the largest motor that can be applied to the SureStart.

Control Input - Any AC/DC voltage that needs to be applied in addition to active supply to SureStart.

Short Circuit Current Rating - This is the maximum fault current that can be applied without damaging the SureStart.

Shutdown on Low Voltage - SureStart will shutdown motor if the supply voltage falls below this threshold.

Shutdown on High Voltage - SureStart will shutdown motor if the supply voltage exceeds this threshold.

Maximum High Voltage - The maximum voltage that can be applied to SureStart.

Maximum Operating Ambient - The maximum temperature the SureStart can properly operate.

Maximum Load Current - This is the maximum current the SureStart is capable of handling.

Minimum Startup Voltage - SureStart will not attempt a motor start if the supply voltage is below this limit.

Software Fault Delay - This is the time delay that will initiate if the SureStart encounters a problem during motor operation.

Initial Power Delay - The time delay from when the SureStart receives power and motor start occurs.

Power Loss Reset - SureStart is designed to turn motor off in the event power is lost for more than this time period.

Contactors Chatter Protection - SureStart can detect faulty contactor conditions and shut the motor off.

Motor Reversal Protection - SureStart will prevent a three-phase motor from reverse rotation in the event of reversal of phase sequence at input supply.

Software Optimization - The maximum number of starts required to achieve optimized motor starting.

Notes

Revision Guide

Pages:	Description:	Date:	By:
All	First Published	24 July 2014	MA



Contact Information:
Hyper Engineering, Pty. Ltd.
9000 Conservation Way
Fort Wayne, IN 46809

www.hypereng.com
sales@hypereng.com
(877) 304-0724

